

MANUFACTURER :- MASCON TECHNEEDS

CLIENT NAME :- -----

CONSULTANT :- -----

PO.NO :- -----

NOTES:-

- 1- DO NOT SCALE THE DWG.
- 2- ALL DIMENSIONS ARE IN MM UNLESS OTHERWISE SPECIFIED.
- 3- GENERAL TOLERANCES = ± 0.2 .
- 4- MATERIAL WILL BE AS PER CUSTOMER REQUIREMENT. EXCEPT FOR STANDARD PARTS.

TECHNICAL SPECS.:-

- Body Test Pressure : 16 Bar.
- Seat Test Pressure : 10 Bar.
- Internal Surface Finish : ≤ 0.4 Micron.
- External Surface finish : As Cast.
- Valve Rating : PN10.
- Actuator Inlet Connection Size : $\frac{1}{4}$ " BSP(F).
- Max. Temperature : STD-120° C.
- Actuating Pressure 5 To 7 Bar.

STANDARD :-

- Designing - BS EN 13397 : 2002,
- Pipe Connection: ASME BPE : 2007,

SEAT :-

- Optional -EPDM, SILICON, VITON .

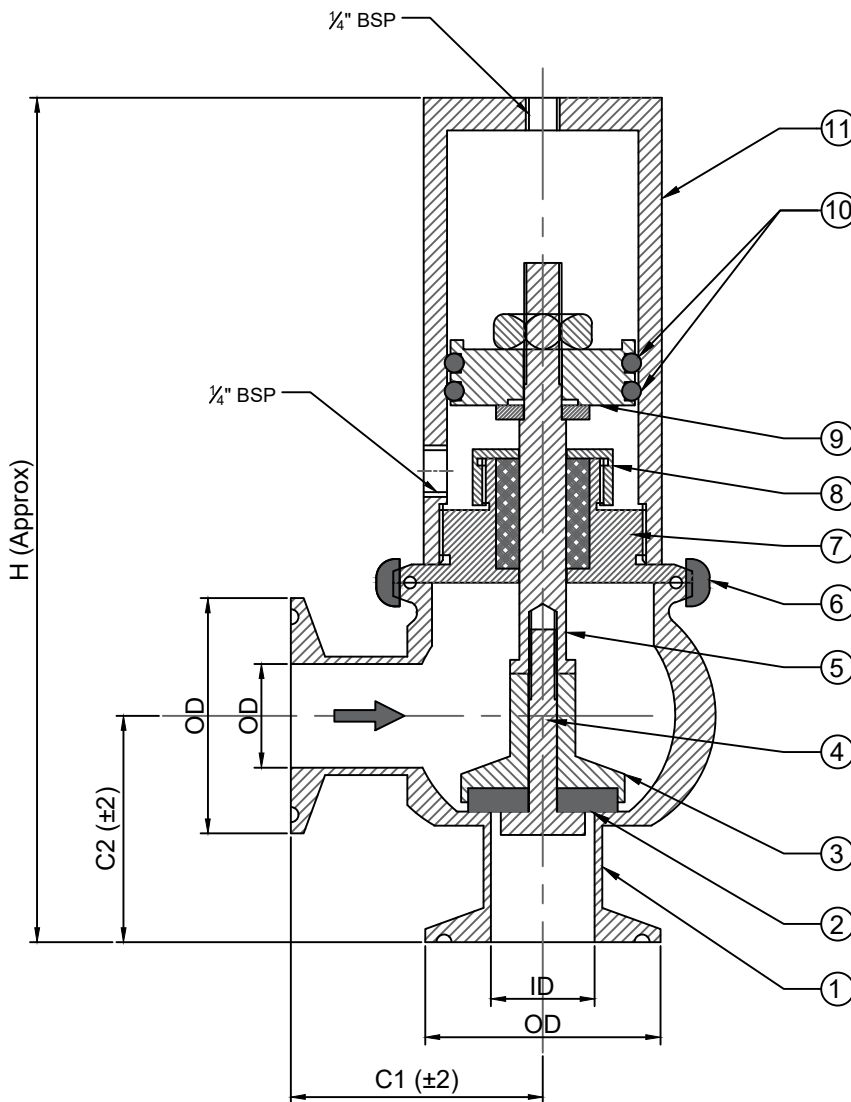

SIZE	C1	C2	ID	OD	H
DN 20	56	48	15.8	50.4	164
DN 25	54	48	22	50.4	164
DN 40	68	58	34.8	50.4	216
DN 50	80	68	47.6	64	234
DN 65	84	69	60.3	77	250
DN 80	91	76	73	91	275

11	ACTUATOR	SS 304	1
10	SEALING RING	NITRILE	2
9	PISTON	AL.	1
8	GLAND NUT	SS 304	1
7	BONNET	SS 316	1
6	TC CLAMP	SS 304	1
5	SPINDLE	SS 316	1
4	BUD CAP LOCK BOLT	SS 316	1
3	BUD CAP	SS 316	1
2	SEAT	OPTIONAL	1
1	VALVE BODY	SS 316L	1
NO	DESCRIPTIONS	MOC	Qty.

DESCRIPTION : HP VALVE

DRAW BY	KALPESH	13/08/2021	FOR :	REV.:- 0
DESIGN BY	SANDEEP	13/08/2021	SCALE : NTS	PROJ.
CHD. BY	SANDEEP	13/08/2021	MODEL: D/HP1P3	
APPD. BY	PRK Sir	13/08/2021	DRG. NO : GA/D/HP1P/13-08-21	

