

MANUFACTURER :- MASCON TECHNEEDS

CLIENT NAME :- -----

CONSULTANT :- -----

PO.NO :- -----

NOTES:-

- 1- DO NOT SCALE THE DWG.
- 2- ALL DIMENSIONS ARE IN MM UNLESS OTHERWISE SPECIFIED.
- 3- GENERAL TOLERANCES = ±0.2.
- 4- MATERIAL WILL BE AS PER CUSTOMER REQUIREMENT. EXCEPT FOR STANDARD PARTS.

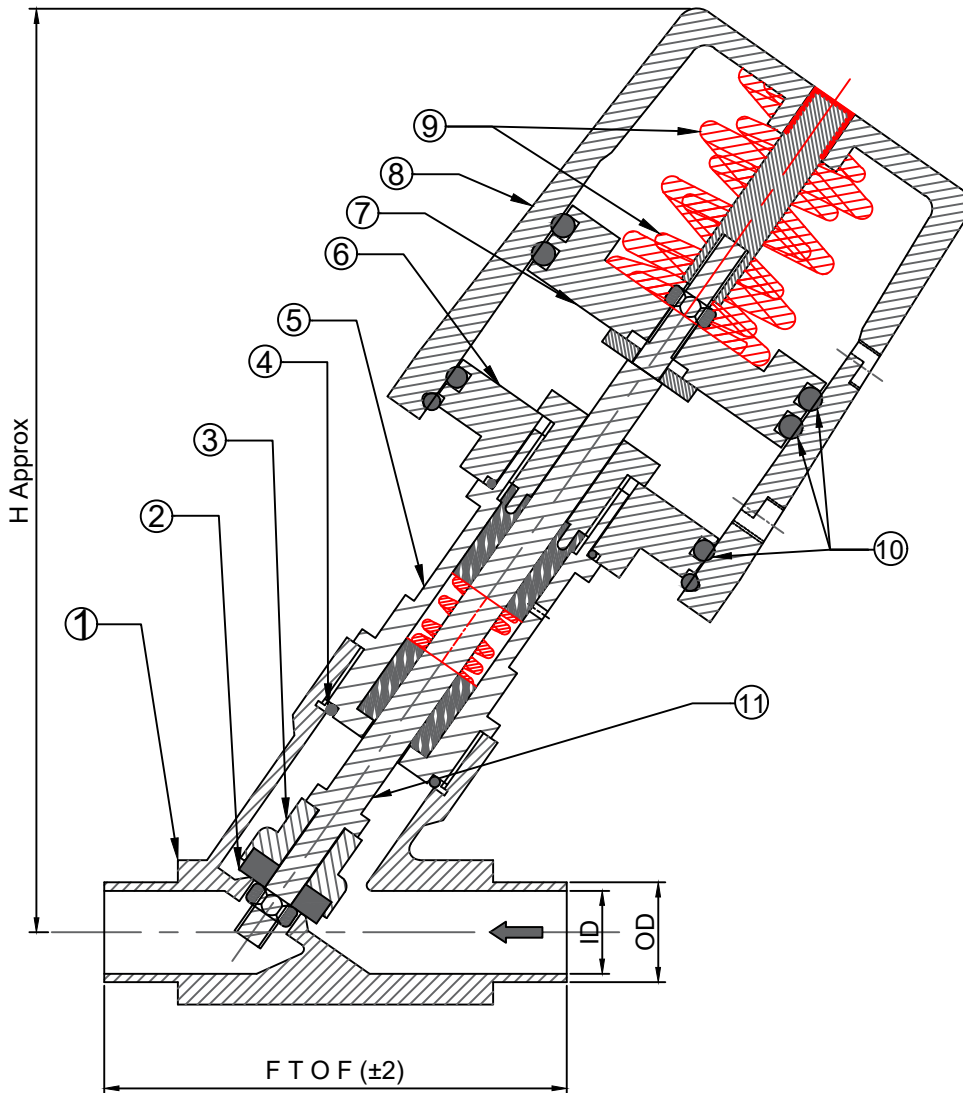

TECHNICAL SPECS.:-

- Body Test Pressure : 16 Bar.
- Seat Test Pressure : 10 Bar.
- External Surface finish : As Cast.
- Valve Rating : PN10.
- Actuator Inlet Connection Size : 1/8" BSP(F).
- Max. Temperature : STD-150° C.
- Actuating Pressure 5 To 7 Bar.

STANDARD :-

- Pipe Connection : ASME BPE : 2007,

Size	F to F	OD	ID	H
DN 15	118	12.7	9.4	176
DN 20	88	19.1	15.8	176
DN 25	100	25.4	22.2	176
DN 40	108	38.1	34.8	200
DN 50	132	50.8	47.6	220
DN 65	178	63.5	60.3	210

11	SPINDLE	SS 316	1
10	SEALING RING	NITRILE	3
9	SPRING	SPRING STEEL	2
8	ACTUATOR	GFN	1
7	PISTON	AL .	1
6	BOTTOM PLATE	AL .	1
5	BONNET	SS 304	1
4	SEALING RING	VITON	1
3	BUD CAP	SS 316	1
2	SEAT	PTFE	1
1	VALVE BODY	SS 316	1
NO	DESCRIPTIONS	MOC	Qty.



DESCRIPTION : PNEUMATIC OPERATED 'Y' TYPE PISTON VALVE.

DRAW BY	KALPESH	13/08/2021	FOR :	REV.:- 0
DESIGN BY	SANDEEP	13/08/2021	SCALE : NTS	SHEET 1 OF 1.
CHD. BY	SANDEEP	13/08/2021	MODEL:212P/BW	PROJ.
APPD. BY	PRK Sir	13/08/2021	DRG. NO : GA/212P/BW/13-08-21	