

MANUFACTURER :- MASCON TECHNEEDS

CLIENT NAME :- -----

CONSULTANT :- -----

PO.NO :- -----

NOTES:-

- 1- DO NOT SCALE THE DWG.
- 2- ALL DIMENSIONS ARE IN MM UNLESS OTHERWISE SPECIFIED.
- 3- GENERAL TOLERANCES = ±0.2.
- 4- MATERIAL WILL BE AS PER CUSTOMER REQUIREMENT. EXCEPT FOR STANDARD PARTS.

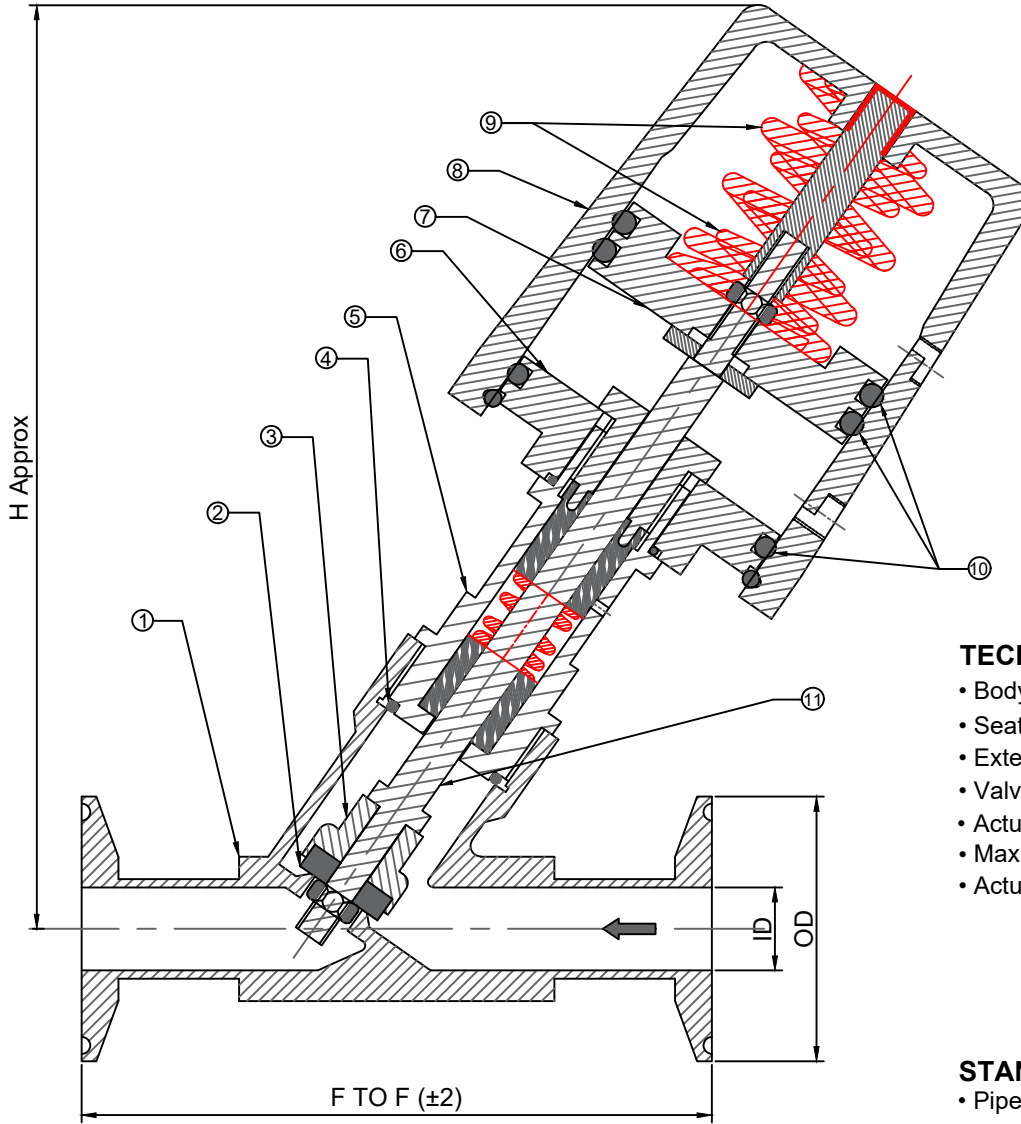

TECHNICAL SPECS.:-

- Body Test Pressure : 16 Bar.
- Seat Test Pressure : 10 Bar.
- External Surface finish : As Cast.
- Valve Rating : PN10.
- Actuator Inlet Connection Size : 1/8" BSP(F).
- Max. Temperature : STD-150° C.
- Actuating Pressure 5 To 7 Bar.

STANDARD :-

- Pipe Connection: ASME BPE : 2007,

NO	DESCRIPTIONS	MOC	Qty.
11	SPINDLE	SS 316	1
10	SEALING RING	NITRILE	3
9	SPRING	SPRING STEEL	2
8	ACTUATOR	GFN	1
7	PISTON	AL .	1
6	BOTTOM PLATE	AL .	1
5	BONNET	SS 304	1
4	SEALING RING	VITON	1
3	BUD CAP	SS 316	1
2	SEAT	PTFE	1
1	VALVE BODY	SS 316	1

Size	F to F	OD	ID	H
DN 15	135	25/50.4	9.4	176
DN 20	119	50.4	15.8	176
DN 25	130	50.4	22.2	178
DN 40	138	50.4	34.8	200
DN 50	162	64	47.6	220
DN 65	178	77	60.3	210



DESCRIPTION : PNEUMATIC OPERATED 'Y' TYPE PISTON VALVE.

DRAW BY	KALPESH	13/08/2021	FOR :	REV.:- 0
DESIGN BY	SANDEEP	13/08/2021	SCALE : NTS	SHEET 1 OF 1.
CHD. BY	SANDEEP	13/08/2021	MODEL:212P/TC	PROJ.
APPD. BY	PRK Sir	13/08/2021	DRG. NO : GA/212P/TC/13-08-21	

