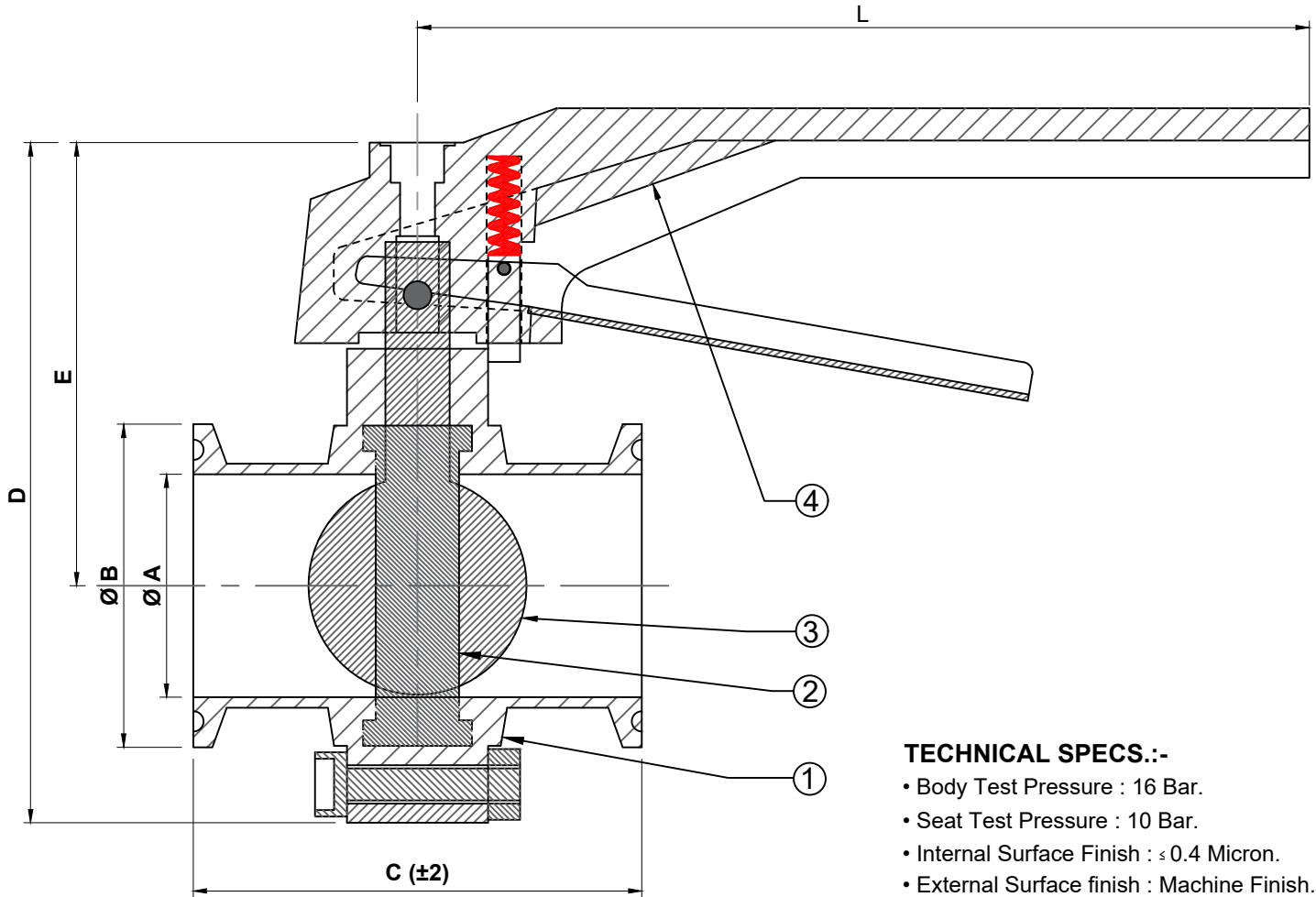

MANUFACTURER :- MASCON TECHNEEDS**CLIENT NAME :- -----****CONSULTANT :- -----****PO.NO :- -----**

NOTES:-

- 1- DO NOT SCALE THE DWG.
- 2- ALL DIMENSIONS ARE IN MM UNLESS OTHERWISE SPECIFIED.
- 3- GENERAL TOLERANCES = ± 0.2 .
- 4- MATERIAL WILL BE AS PER CUSTOMER REQUIREMENT. EXCEPT FOR STANDARD PARTS.

**TECHNICAL SPECS.:-**

- Body Test Pressure : 16 Bar.
- Seat Test Pressure : 10 Bar.
- Internal Surface Finish : ≤ 0.4 Micron.
- External Surface finish : Machine Finish.
- Valve Rating : PN10.
- Max. Temperature : STD-120° C.

STANDARD :-

- Designing - BS EN 13397 : 2002,
- Pipe Connection: ASME BPE : 2007,
- Face to Face : BS EN 558-1 :1996.

SIZE	A	B	C	D	E	L
DN25	22.1	50.4	66	89	48	167
DN40	34.8	50.4	70	89	48	167
DN50	47.5	64	71	105	68	167
DN65	60.2	77	74	115	70	167
DN80	72.2	91	75	133	88	167
DN100	97.5	119	100	188	109	167

NO	DESCRIPTIONS	MOC	Qty.
4	HANDLE	GFN	1
3	FLAP	SS 316L	1
2	SLEAVE	SILICON	1
1	VALVE BODY	SS 316L	1

DESCRIPTION : MANUAL OPERATED BUTTERFLY VALVE.

DRAW BY	KALPESH	21/01/2022	FOR :	REV.:- 0
DESIGN BY	SANDEEP	21/01/2022	SCALE : NTS	SHEET 1 OF 1.
CHD. BY	SANDEEP	21/01/2022	MODEL: 44S1	PROJ.
APPD. BY	PRK Sir	21/01/2022	DRG. NO : GA/44S1/21-01-22	

